



September 2022 Edition

SOUND 申达



ZHEJIANG SOUND MACHINERY MANUFACTURE CO.,LTD.

Add: No.208 Zhuantang Village, Xihu District,
Hangzhou City, Zhejiang Province, CHINA
Domestic Sales Dept
TEL: +86-572-8232315 8232103
FAX: +86-572-8232191
International Sales Dept.
TEL: +86-572-8232131
FAX: +86-572-8232291
After-sales Service
TEL: +86-572-8232023
FAX: +86-572-8232023

DEQING SOUND MACHINERY MANUFACTURE CO.,LTD.

Add: No.618 North Huancheng Road, Fu'xi District,
Deqing, Huzhou City, Zhejiang Province, CHINA

www.injectionmachine.com

UNIVERSE Series

The 3rd Generation High-efficiency
Precision Injection Molding Machine

ZHEJIANG ARTIKING GROUP • ZHEJIANG SOUND MACHINERY MANUFACTURE CO.,LTD.

ENTERPRISE INTRODUCTION

Founded in 1955, ZHEJIANG SOUND MACHINERY MANUFACTURE CO., LTD is one of the earliest professional manufacturers of injection molding machine in China, which is affiliated to ZHEJIANG ARTIKING GROUP CO., LTD . SOUND is the pioneer of China's plastic machinery industry, the first batch of national high-tech enterprises in the industry, the key enterprise of "a Group of Five" in Zhejiang province. SOUND has won the only National Silver Award in domestic plastic machinery industry, the second prize of National Science and Technology Progress Award, the first prize of Zhejiang Science and Technology Progress Award, etc. SOUND has scientific research institutions such as academician expert workstation, national post-doctoral scientific research workstation, provincial enterprise research institute, provincial enterprise technology center and provincial engineering research center. SOUND has obtained more than 180 patents and 16 invention patents.

In 2020, DEQING SOUND manufacturing base, with a total investment of RMB700 million and a covering area of 133,000m², had been completed and put into production. The base is equipped with more than 70 sets first-class processing equipments and testing equipments, including Czech SKODA floor-type boring and milling machining center, Japanese NIIGATA FMS flexible machining system, Japanese KURAKI planer table-type boring and milling machining center, Japanese Mitsubishi Gantry pentahedron machining center, Japanese OKUMA CNC lathe, Italian HEXAGON CMM three-coordinate measuring machine. It can achieve an annual production capacity of more than 6,000 sets injection molding machines.

SOUND successfully launched the 3rd generation high-efficiency precision universe series (UN), dual-plate series (DP), full electric series (FE), electric mixed hydraulic series (EMH), extrusion-injection integrated series for large volume (FJ), multi-component series and nearly 100 special models machine. The clamping force of machines is from 1,000KN to 60,000KN, and shot weight is from 100g to 550,000g. SOUND had exported the injection molding machines to more than 60 countries and regions such as Japan, France, Saudi Arabia, India, Indonesia, Russia and USA.

Facing the future, SOUND insists on customer-oriented, employee-oriented, innovation as the source, constantly surpassing itself and creating value, focusing on the one-stop overall solution for the future injection molding factory, and making SOUND a benchmark enterprise for intelligent manufacturing in the plastic injection machinery industry.



SOUND

Extreme | Meticulous | Preciseness

Provide you with a one-stop injection molding solution with high adaptability and cost-effectiveness!

Since in 1955, SOUND has been committed to creating the highest value for customers with high-quality, high-efficient and high-precise products for more than 60 years.

The Universe 3rd generation high-efficiency precision injection molding machine inherits the excellent genes of SOUND and was carefully built by the Japanese team. With large parameters, high adaptability and high cost-effectiveness, Universe series machine has become your reliable product to meet your production requirements of high-quality and high-efficiency, and to create the highest value for you!

High Quality

Large parameters for all known injection molding processes, wide application range. According to the Japanese modularization, life management design and meticulous production, high quality, high cost-effective, personalized configuration. Dual crank arm clamping structure, solid, stable, reliable and durable, suitable for 24-hour uninterrupted work.

High Efficient

High Efficient servo driver technology ensures high quality and high efficient production even after the cycle time is shortened. Multiple technologies ensure the independent action of each motion axis, making high efficient and energy-saving production so simple. High quality components are durable enough and capable of long-term efficient operation without frequent maintenance.

High Precision

Repeatability accuracy of mold opening and closing position $\pm 0.5\text{mm}$
Repeatability accuracy of shot weight 0.7% - 0.3%

Energy Saving

High efficient drive technology, modular design of hydraulic valve plates, excellent hydraulic layout, non-overflow and non-fever servo pump control system, high-efficient built-in cooler, DIN standard hydraulic connectors and hoses make energy saving a daily reality..



High Quality | High Efficient | High Precision | Energy Saving

HIGH EFFICIENCY ENERGY SAVING

Large Toggle Stroke

Large Parameter
High Adaptability
(under the same clamping force condition)

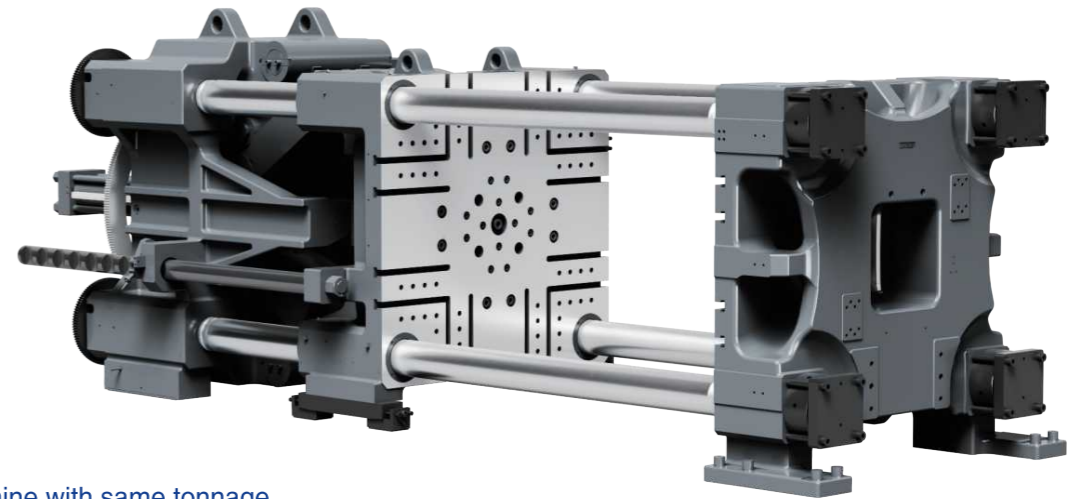

For the machine with same tonnage,
toggle stroke is larger than other competitors,
which is convenient for installing bigger mold.

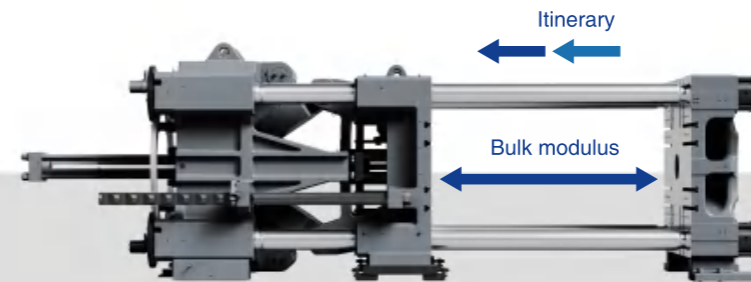

Large Space Between Tie Bars:
Suitable for big and small molds,
and the molds are widely applicable.

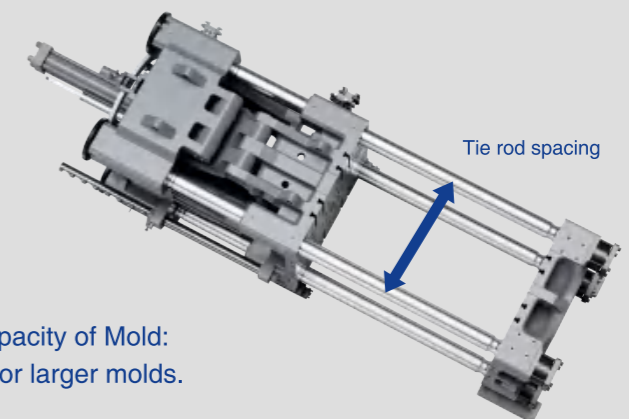

Large Capacity of Mold:
Suitable for larger molds.

Large Toggle Stroke

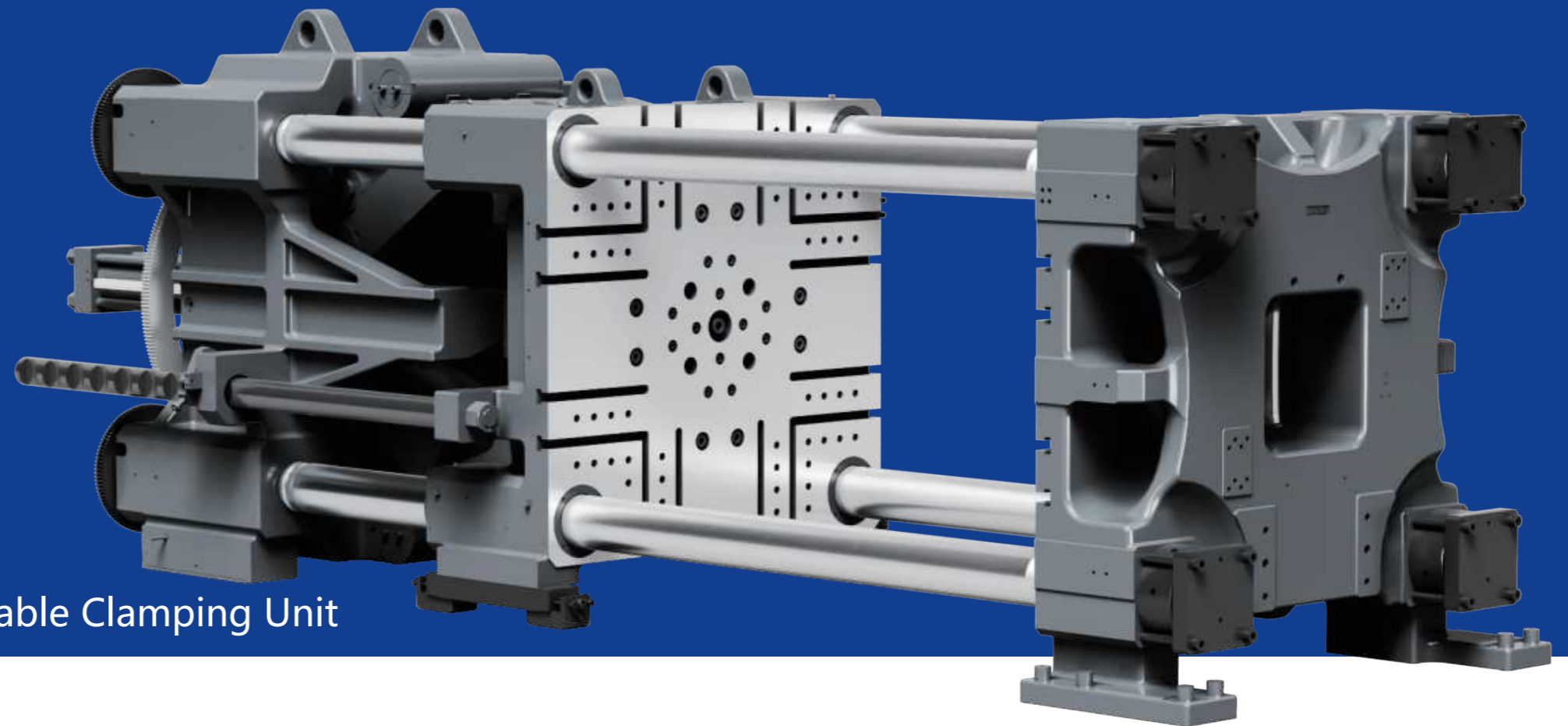

High Quality

High Quality, Stable and Reliable Clamping Unit

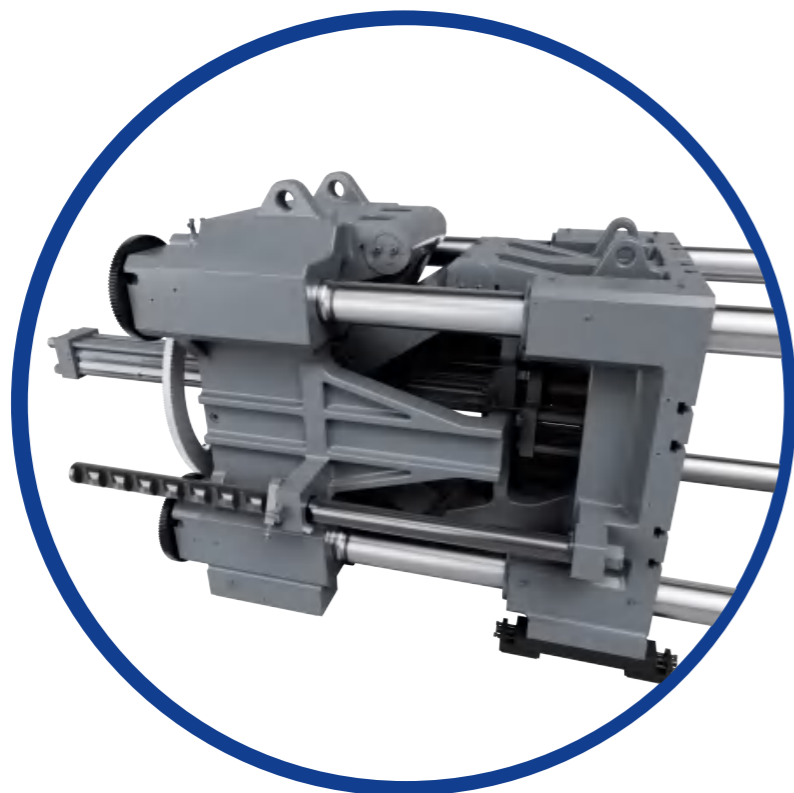

The large drawing lines of the clamping part are marked with the following selling points:

- Dual crank arm clamping structure, it is solid, stable, reliable and durable, suitable for 24-hour uninterrupted work.
- The whole series configure T-slot & threaded hole mold platen as standard, which makes mold replacement faster and more convenient, effectively solving the problem of easy damage to the thread of the threaded hole platen
- The centrally reinforced moving platen and front platen design, can transmit the force to the mold in a concentrated manner, then the mold is less deformed due to the concentrated force, which can prolong the working life of the mold
- The clamping unit adopts differential technology to realize fast mold opening and closing to ensure the cycle time of the product.
- European style portable ejector structure design, easy to disassemble and maintain the ejector pin.
- The lengthened and widen sliding foot guide ensures high parallelism of the platen and high repeat positioning accuracy, more stable and faster mold opening and closing, to ensure the whole machine more stable and high efficient.
- The self-lubricating steel ring and copper ring reduce lubrication requirements, reduce lubricating oil consumption, reduce wear and prolong the working life of the whole machine.
- Inheriting Japanese modularization, life management design and meticulous production, reliable materials with good mechanical rigidity to ensure the working life of the whole machine.

- The whole machine adopts high performance hose and DIN standard hydraulic joint, no welding, no oil leakage, no pollution.
- Multi-pump combination technology, electric servo injection technology and hydraulic accumulator technology realize the independent action of each motion axis, making high efficient production so simple.
- Through the hydraulic expansion combination to achieve a short cycle. Strong selectivity and high cost performance to meet the requirements of different customers.
- High Efficient servo system + internal gear pump, output energy consumption varies with load, closed-loop control of pressure and speed, faster response (30-50ms). The system pressure 17.5Mpa, injection pressure and speed are greatly improved.
- Modular design of hydraulic valve board + excellent hydraulic layout, effectively reduce pressure loss, improve the response speed, and make function upgrade and oil circuit transformation easy.
- Non-overflow and non-fever servo pump control system + high-efficiency built-in cooler, which greatly reduces water consumption and greatly saves energy.
- The nearby hydraulic control system ensures the quick response of injection.

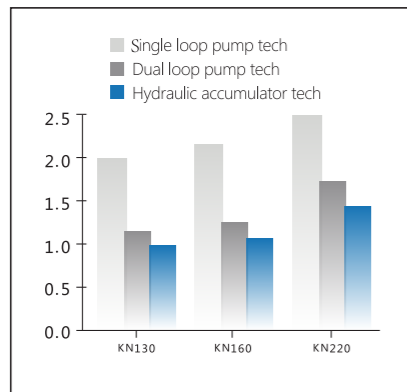

Through hydraulic expansion combination to achieve a shorter cycle time.

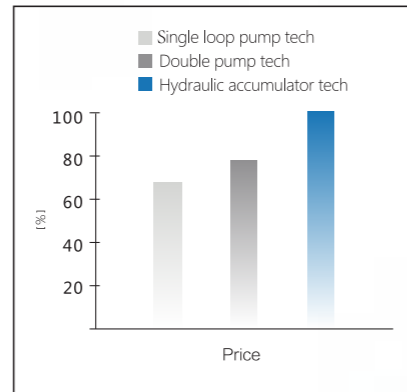

High performance-price ratio satisfy the requirements of different customers.

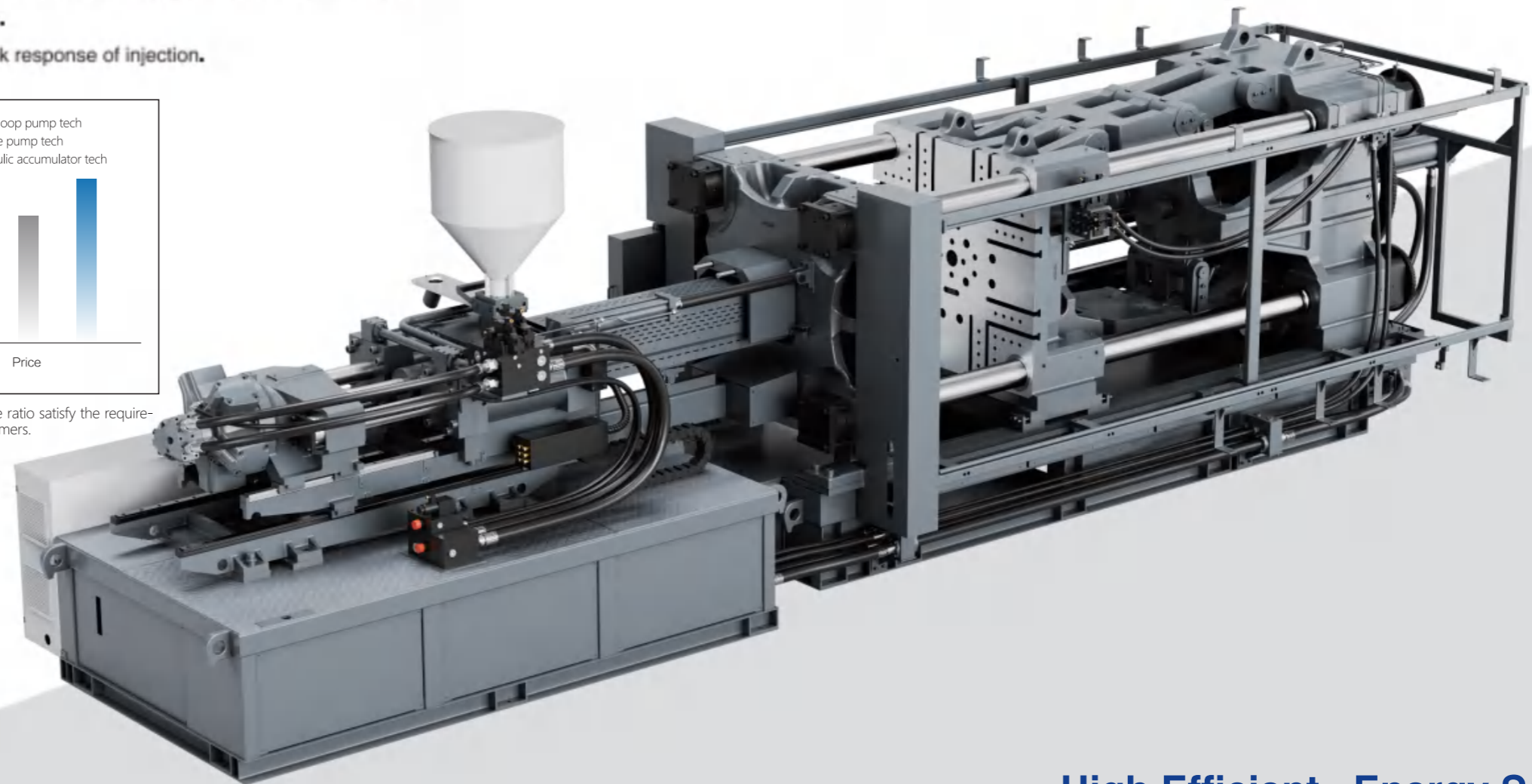

High Efficient Energy Saving

HIGH EFFICIENCY ENERGY SAVING

Repeatability Accuracy of Shot Weight 0.7% - 0.3%

- The Universe series injection unit adopts a double-layer injection structure, and the injection cylinder with double-outstretched rod structure of high-speed machine structure,
- which greatly improves the injection accuracy and charging stability.
- The whole series adopt high rigid injection base and high precision linear slide rail, making injection response more rapid, accurate and stable.
- The movement of injection unit adopts high-rigidity guide column structure + double injection movement structure to avoid material leakage during charging time of high-speed, high-pressure injection and high back pressure.
- PRS position adjustment screw technology to achieve accurate shot weight and ensure the shot weight repeatability accuracy of 0.7%-0.3%.

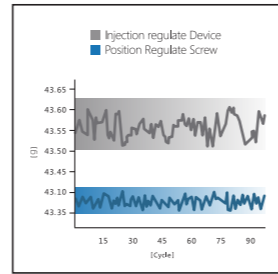

repetition precision: achieve accurate shot weight through PRS function

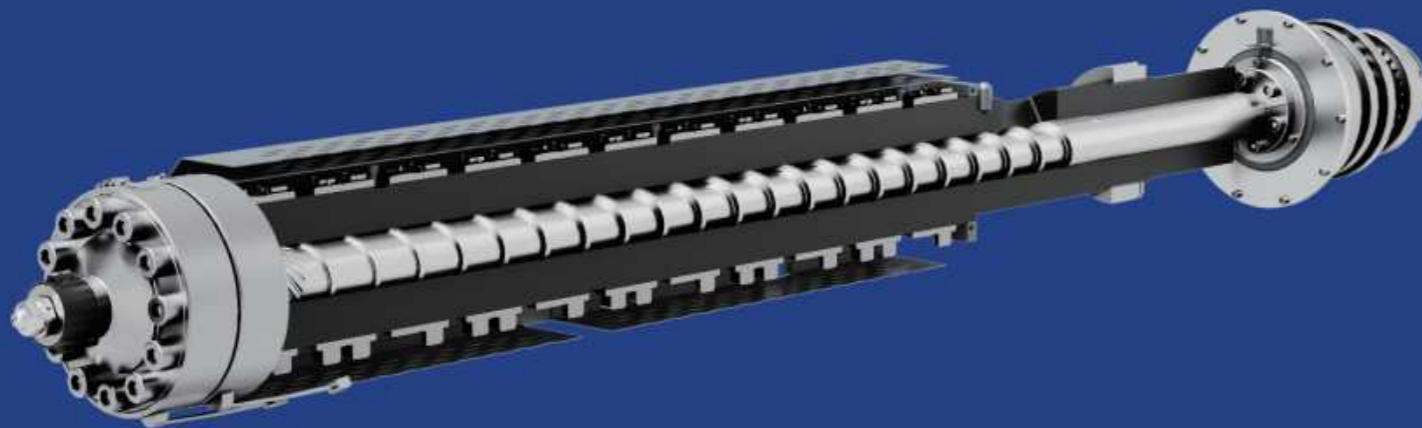

SSR barrel temperature control system:

- Using non-contact control, once the raw material enters the feeding area, it has been incorporated into the temperature closed-loop control unit, which effectively improves the accuracy and efficiency of the injection unit, and avoids the phenomenon of low injection precision caused by raw material caking and unsmooth feeding at the same time.

Roller slide structure, convenient for changing plastic materials

High Adaptability Plasticizing System:

- High-performance screws with different screw diameters, wear-resistant grades, geometric shapes and special mixing requirements to meet customer's individual needs.
- The special plasticizing system can be customized for various complex process requirements and various application requirements.
- Adopt high-torque and high-speed hydraulic plasticizing motor, fast response speed and energy saving. (Option: Choose electric charging if need better enger-saving effect)
- The precision of Japan and the rigor of Germany are combined with local manufacturing.
- The standard injection speed meets the requirements of European standard, with fast speed and accurate position. The product has less internal stress and stable quality.

- The whole series machines configure large-screen controller as standard, friendly UI interface, and better conveying information.
- Standard SPC quality control and management system to help achieve continuous stability and redicatability of the process, improve production capacity, product quality and reduce costs.
- SVP servo pump, accurately control response speed, convenient system maintenance, energy saving.
- Powerful software control function makes the complicated injection molding process simple and easy to operate.
- The main electrical components are all imported brands such as Schneider, ABB, Fuji, Eaton, etc., which greatly improves the working life and stability.
- The expansion interface of Industry 4.0 of human-computer interaction is available, to open a new era of smart factory. (Remark: U77, OPC, etc., MES requires additional charges) .
- The automated, intelligent and modern injection molding machine computer is conducive to central data collection, analysis and backup. At the same time, it can realize data interaction and full-line automation with robot, mold temperature controller, chiller and other auxiliary machines, forming an exclusive customer IoT (Internet of things) management solution of injection molding machine.
- Friendly amd simple operating software is convenient for users to master the machine producing status anytime and anywhere, and respond quickly and timely, to ensure high-efficient production process and high-quality output.



Specification

DESCRIPTION	UNIT	UN100-EPIII	UN140-EPIII	UN180-EPIII	UN230-EPIII
International Size Rating		350	430	600	900

INJECTION UNIT

		UN100-EPIII	UN140-EPIII	UN180-EPIII	UN230-EPIII								
screw specification	mm	32	36	40	36	40	45	40	45	50	45	50	55
Screw L:D ratio		22.5	20.0	18.0	22.2	20.0	17.8	22.5	20.0	18.0	22.2	20.0	18.2
Shot volume	cm ³	145	183	226	204	251	318	283	358	442	398	491	594
Shot weight(PS)	g	132	167	206	185	229	289	257	326	402	362	447	541
	oz	4.6	5.9	7.3	6.5	8.1	10.2	9.1	11.5	14.2	12.8	15.8	19.1
Injection pressure	Bar	2222	1755	1422	2154	1745	1378	2231	1763	1428	2299	1862	1539
Injection rate	cm ³ /s	76	96	118	98	120	152	118	149	184	146	180	218
Plasticizing capacity	g/s	8.4	13.1	20.7	13.6	21.5	28.3	20.2	26.6	31.9	22.7	27.2	33.2
Max.screw speed	r/min	277			293			275				231	

CLAMPING UNIT

		UN100-EPIII	UN140-EPIII	UN180-EPIII	UN230-EPIII
Clamping force	KN	1000	1400	1800	2300
Space between tie bars(H×V)	mm	410X360	460X410	520X470	570X520
MIN.mold dimension(H×V)	mm	310X310	340X340	380X380	430X430
Toggle stroke	mm	350	400	460	520
Min.mold height	mm	150	170	200	220
Max.mold height	mm	400	480	550	570
Distance between platens(daylight)	mm	750	880	1010	1090
Ejector stroke	mm	110	130	130	150
Ejector force	KN	40	49	49	77
Number of ejector	Pcs	5	5	5	9

POWER UNIT

		UN100-EPIII	UN140-EPIII	UN180-EPIII	UN230-EPIII
System pressure	Bar	175	175	175	175
Pump motor	kW	11	15	18	22
Heating capacity	kW	6.3	7.5	11.5	14.0

GENERAL

		UN100-EPIII	UN140-EPIII	UN180-EPIII	UN230-EPIII
Oil tank capacity	L	120	150	200	240
Machine dimension(L×W×H)	m×m×m	4.2X1.1X1.8	4.4X1.2X1.9	5.1X1.3X2.0	5.4X1.4X2.2
Machine weight	t	3.3	4.3	5.5	7
Hopper capacity	kg	25	25	50	50

Mold Platen Drawing

UN100-EPIII

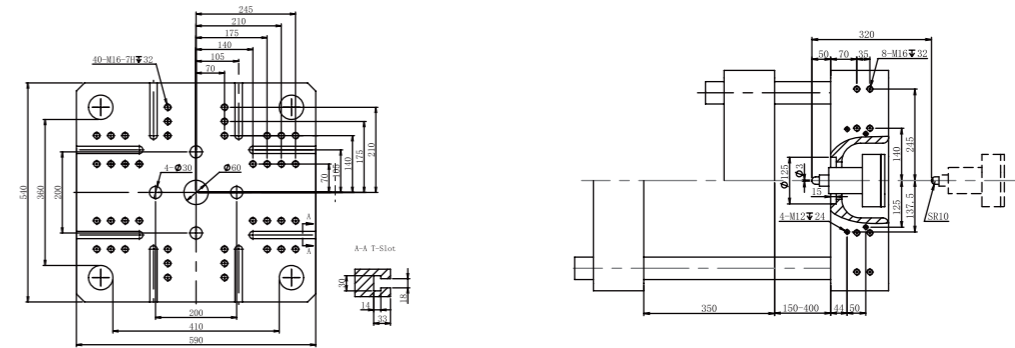

UN140-EPIII

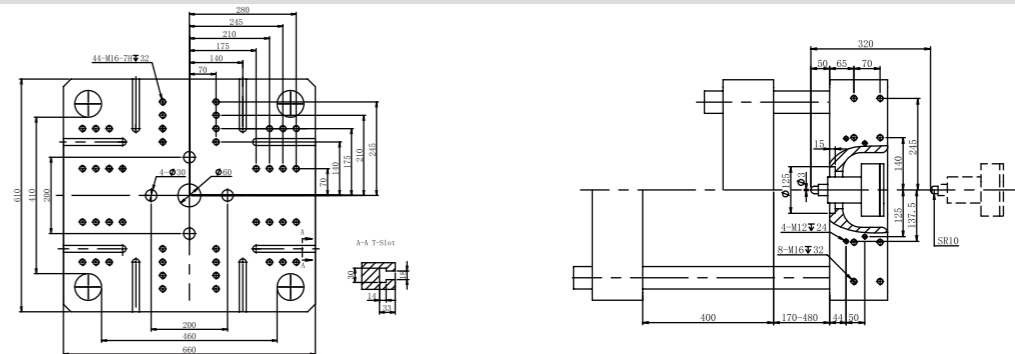

UN180-EPIII

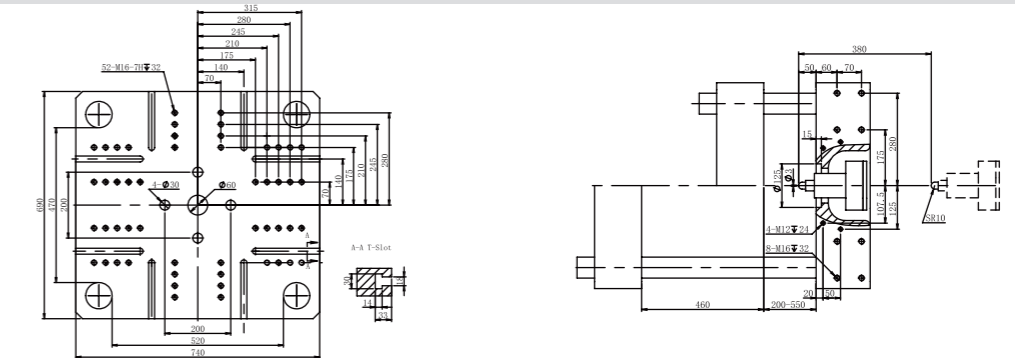

UN230-EPIII

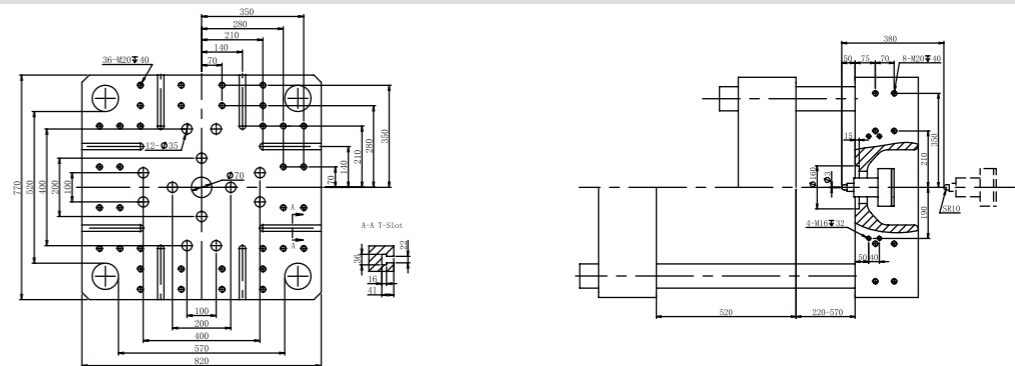

Specification

DESCRIPTION	UNIT	UN270-EPIII	UN300-EPIII	UN350-EPIII	UN420-EPIII
International Size Rating		1400	1800	2300	2700

INJECTION UNIT

	UNIT	55	60	65	60	65	70	65	70	75	70	75	80
screw specification	mm												
Screw L:D ratio		21.8	20.0	18.5	21.7	20.0	18.6	21.5	20.0	18.7	22.5	21.0	19.7
Shot volume	cm ³	713	848	995	919	1078	1251	1161	1347	1546	1443	1657	1885
Shot weight(PS)	g	649	772	906	836	981	1138	1057	1226	1407	1313	1508	1715
	oz	22.9	27.2	32.0	29.5	34.6	40.1	37.3	43.2	49.6	46.3	53.2	60.5
Injection pressure	Bar	2036	1711	1458	2013	1715	1479	1988	1714	1493	1857	1618	1422
Injection rate	cm ³ /s	206	245	288	287	337	391	290	337	387	389	446	508
Plasticizing capacity	g/s	31.2	39.7	48.2	43.6	53.0	62.3	44.2	51.9	64.9	48.7	60.9	68.2
Max.screw speed	r/min		200			220			183			172	

CLAMPING UNIT

Clamping force	KN	2700	3000	3500	4200
Space between tie bars(H×V)	mm	620X570	670X620	730X670	770X720
MIN.mold dimension(H×V)	mm	450X450	500X500	550X550	600X600
Toggle stroke	mm	560	610	660	740
Min.mold height	mm	250	250	250	300
Max.mold height	mm	600	650	700	750
Distance between platens(daylight)	mm	1160	1260	1360	1490
Ejector stroke	mm	150	170	170	220
Ejector force	KN	77	95	95	120
Number of ejector	Pcs	13	13	13	17

POWER UNIT

System pressure	Bar	175	175	175	175
Pump motor	kW	30	37	37	45
Heating capacity	kW	16.0	20.0	23.0	28.0

GENERAL

Oil tank capacity	L	300	400	400	500
Machine dimension(L×W×H)	m×m×m	6.0X1.5X2.2	6.5X1.6X2.3	7.0X1.7X2.4	7.7X1.85X2.4
Machine weight	t	8	975	12.5	16
Hopper capacity	kg	75	75	75	100

Mold Platen Drawing

UN270-EPIII

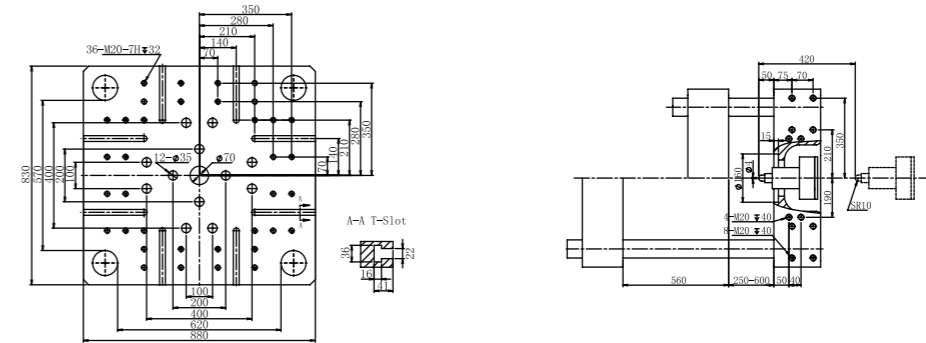

UN300-EPIII

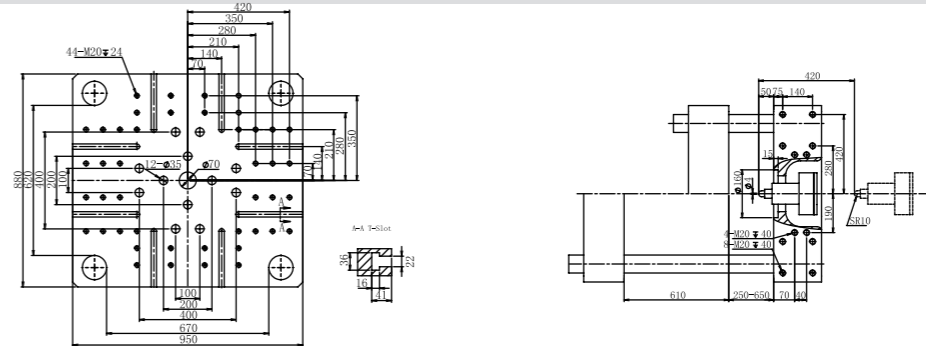

UN350-EPIII

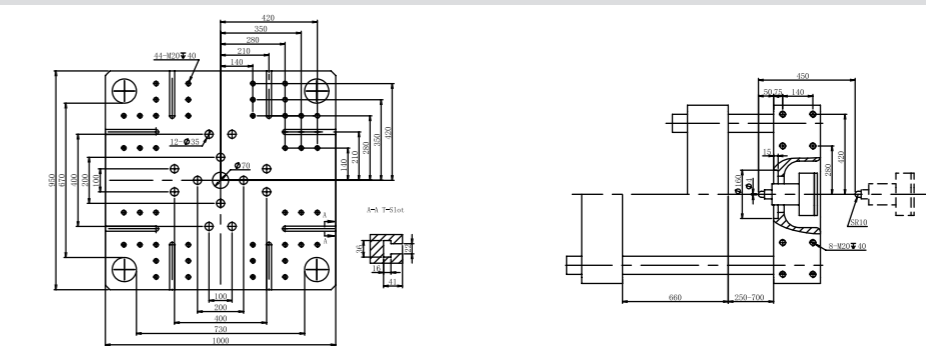

UN420-EPIII

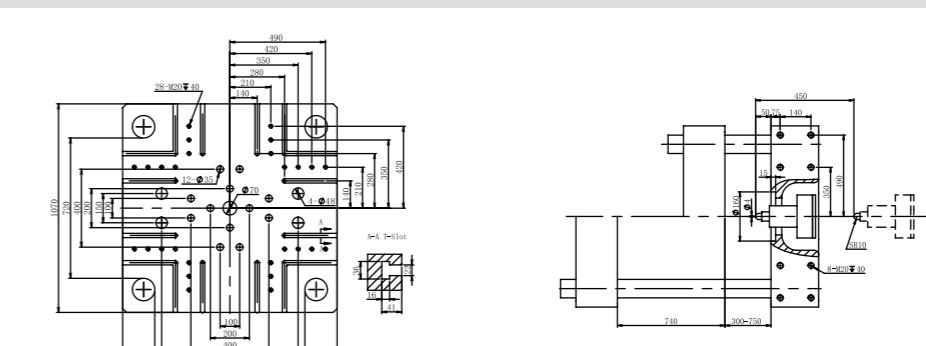

Specification

DESCRIPTION	UNIT	UN530-EPIII	UN600-EPIII	UN700-EPIII	UN850-EPIII	UN1050-EPIII
International Size Rating		3450	4450	5900	7500	9600

INJECTION UNIT

screw specification	mm	75	80	85	90	80	85	90	100	85	90	100	110	90	100	110	120	100	110	120	130
Screw L:D ratio		22.4	21.0	21.2	20.0	22.3	21.0	22.2	20.0	22.2	21.0	22.0	20.0	23.3	21.0	21.8	20.0	23.1	21.0	21.7	20.0
Shot volume	cm ³	1878	2136	2412	2704	2262	2554	2863	3534	2837	3181	3927	4752	3372	4163	5037	5994	4555	5512	6560	7698
Shot weight(PS)	g	1709	1944	2195	2460	2058	2324	2605	3216	2582	2895	3574	4324	3068	3788	4583	5455	4145	5016	5969	7006
	oz	60.3	68.6	77.4	86.8	72.6	82.0	91.9	113.4	91.1	102.1	126.1	152.5	108.2	133.6	161.7	192.4	146.2	176.9	210.6	247.1
Injection pressure	Bar	1848	1624	1439	1283	1969	1744	1556	1260	2078	1854	1502	1241	2224	1802	1489	1251	2128	1759	1478	1259
Injection rate	cm ³ /s	500	569	642	720	528	596	668	825	570	639	788	954	623	769	931	1108	773	936	1114	1307
Plasticizing capacity	g/s	62.3	69.8	82.3	104.7	69.8	82.3	104.7	129.7	75.3	95.8	118.7	148.3	101.3	125.5	156.8	188.2	88.8	106.6	118.4	163.8
Max.screw speed	r/min	176		176		161		170		139											

CLAMPING UNIT

Clamping force	KN	5300		6000		7000		8500		10500											
Space between tie bars(H×V)	mm	870X820		920X870		1000X950		1120X1020		1220X1120											
MIN.mold dimension(H×V)	mm	650X650		700X700		750X750		900X900		950X950											
Toggle stroke	mm	850		910		980		1100		1250											
Min.mold height	mm	350		400		400		450		500											
Max.mold height	mm	800		880		980		1000		1160											
Distance between platens(daylight)	mm	1650		1790		1960		2100		2410											
Ejector stroke	mm	250		250		280		280		320											
Ejector force	KN	166		160		197		197		230											
Number of ejector	Pcs	17		21		21		21		21											

POWER UNIT

System pressure	Bar	175		175		175		175		175											
Pump motor	kW	55		67		75		85		105											
Heating capacity	kW	33/36		36/42		40/49		60/65		72/82											

GENERAL

Oil tank capacity	L	650		700		800		1100		1200											
Machine dimension(L×W×H)	m×m×m	9.0X2.15X2.6		9.5X2.3X2.7		10X2.45X2.8		11X2.7X3.2		11.8X2.8X3.6											
Machine weight	t	20.5		25.5		33.5		40		50											
Hopper capacity	kg	100		100		150		150		200											

Mold Platen Drawing

UN530-EPIII

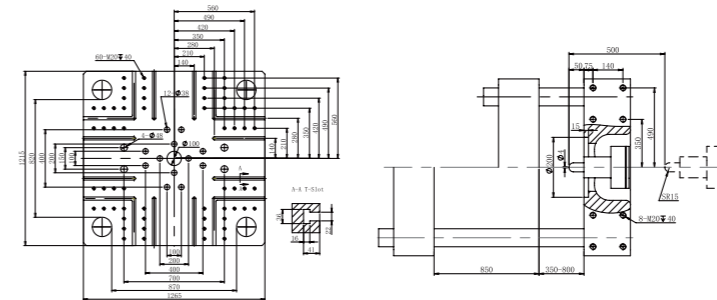

UN600-EPIII

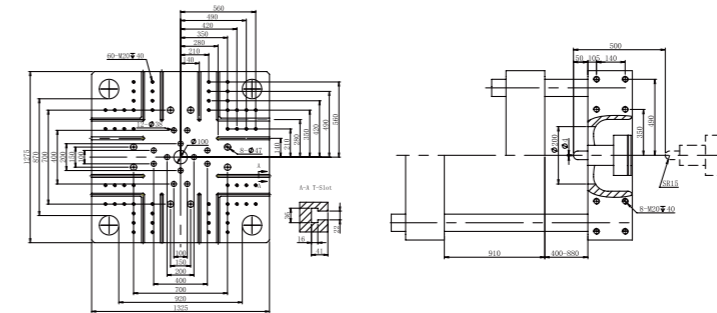

UN700-EPIII

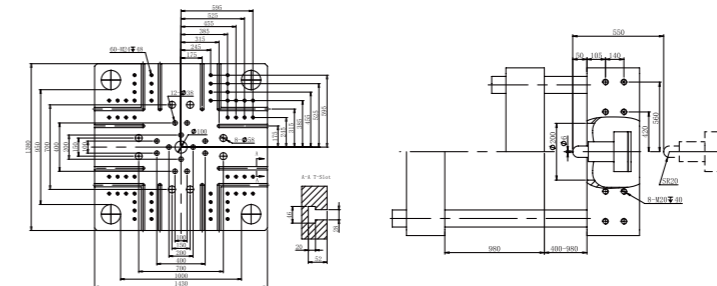

UN1050-EPIII

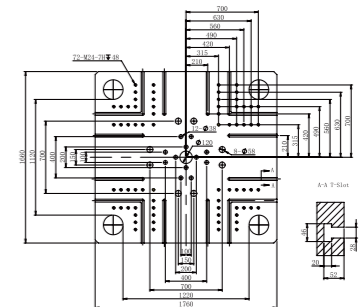

UN850-EPIII

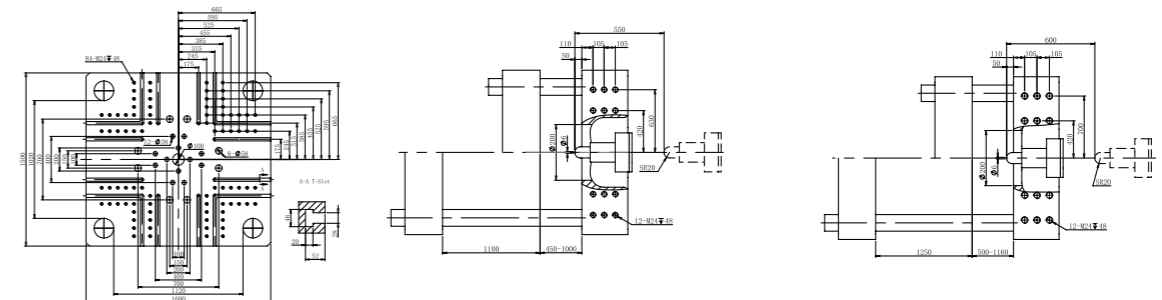

Feature Description	Models			
Injection Part	UN100-350EPIII	UN420-530EPIII	UN600-700EPIII	UN850-1050EPIII
BI-metal Screw: B, C, D screw + nitriding barrel	●	●	●	●
Chrome plated screw: A screw + nitriding barrel	●	●	●	●
BI-metal Screw&barrel	○	○	○	○
Full hard screw + BI-metal barrel	○	○	○	○
High wear resistance and corrosion resistant screw, barrel	○	○	○	○
Needle shur-off nozzle	○	○	○	○
Hydraulic/air shut-off nozzle	○	○	○	○
Balanced dual cylinder injection unit	●	●	●	●
Balanced dual cylinder carriage unit	●	●	●	●
High rigid double layer injection system	●	●	●	●
Injection unit increase&decrease	○	○	○	○
Hydraulic motor increase	○	○	○	○
Electric charging	○	○	○	○
Ejectric injection	○	○	○	○
Accumulator injection	○	○	○	○
Injection transducer	●	●	●	●
Nozzle transducer	○	○	○	○
Screw speed display	●	●	●	●
Feeding mould temp. auto controlled	○	○	○	○
Ceramic heater	●	●	●	●
Infrared heating	○	○	○	○
Fan cooler	○	○	○	○
Auto material cleaning	●	●	●	●
Cold start protection	●	●	●	●
Nozzle cover	●	●	●	●
Centralized Lubrication device in injection unit	○	○	○	○
Proportion back pressure	○	○	○	○
Servo valve device	○	○	○	○
Clamping Unit				
T-slot mold plate	●	●	●	●
Magnet mold plate	○	○	○	○
Mold thickness increase (Min-mold thickness equal increased)	○	○	○	○
Mold thickness reduce (Max-mold thickness equal increased)	○	○	○	○
Mechanical&electrical safety device	●	●	●	●
Clamping, eject transducer	●	●	●	●
Product slide with photo cell	○	—	—	—
Mold adjustment limited switch	●	●	●	●
Auto mold adjustment function	●	●	●	●

Remarks: "●" standard, "○" option, "—" No

Feature Description	Models			
Clamping Unit	UN100-350EPIII	UN420-530EPIII	UN600-700EPIII	UN850-1050EPIII
Clamping force display	○	○	○	○
Clamping force control close-loop	○	○	○	○
Widen safety door	○	○	○	○
Auto safety door	○	○	○	●
Safety step board in mold zone	○	○	○	○
Safety light curtain in mold zone	○	○	○	●
Separated type machine body	—	—	●	●
Mold lifting hanger	○	—	—	—
Quantitative centralized lubrication device	●	●	●	●
Glass tube cooling Flowmeter	○	○	○	○
Quick plug distributor	●	●	●	●
Hydraulic&electric unscrew eject	○	○	○	○
Air valve (2 unit from UN850)	○	○	○	●
Core pulling (2 unit from UN420)	●	●	●	●
Electric or Hydraulic Unscrew device	○	○	○	○
Unscrewing counter sensor	○	○	○	○
Mold open&closed proportional valve	○	○	○	○
Synchronous action (ejector, core pulling)	○	○	○	●
Valve control in proper order	○	○	○	○
Product QS function device	○	—	—	—
Thermal baffle	○	○	○	○
Hydraulic Unit				
Servo Motor/pump control system	●	●	●	●
Self-sealing magnetic oil sucking filter	●	●	●	●
Pump/motor power increase	○	○	○	○
Cooler increase	○	○	○	○
Oil temperature display	●	●	●	●
Oil temp auto control	○	○	○	○
Oil level alarm	○	○	○	○
Oil temp. pre-heating function	○	○	○	○
Oil tank magnet	●	●	●	●
High pressure on-line filter	○	○	○	○
Low presure return filter	○	○	○	○
Passby oil filter	○	○	○	○

Remarks: "●" standard, "○" option, "—" No.
mold cooling: 6 ways loop (less UN230), 10 ways loop (UN270-UN700) ,12 ways loop(UN850-UN1050)

Feature Description	Models			
	UN100-350EPIII	UN420-530EPIII	UN600-700EPIII	UN850-1050EPIII
Electric Unit				
Techmation 8" color screen	●	○	○	○
KEBA 12" color screen	○	●	●	●
Action monitoring function	●	●	●	●
Producing monitoring function	●	●	●	●
Error alarm display	●	●	●	●
Hardware input output function	●	●	●	●
Euromap 12 robot interface	○	○	○	○
Euromap 67 robot interface	○	○	○	○
3 color alarm light	●	●	●	●
Rear safety door emergency button	●	●	●	●
SSR for heating	●	●	●	●
3phase-5line socket(16A)	●	○	○	○
3phase-5line socket(32A)	○	●	●	●
Single phase socket (10A)	●	●	●	●
European 3phase-5line socket(16A)	○	○	○	○
European 3phase-5line socket(32A)	○	○	○	○
European single phase socket (10A)	○	○	○	○
Hot runner control system and interface	○	○	○	○
Internet manage system	○	○	○	○
Other				
Nomal hopper	●	●	●	●
Toolbox/damageable spare parts/operation manual	●	●	●	●
Level pad	●	●	●	●
Mold clamping board	●	●	●	●
Stainless steel hopper	○	○	○	○
Hopper dryer	○	○	○	○
Hopper magnet	○	○	○	○
Special color	○	○	○	○
Robot	○	○	○	○
Water chiller	○	○	○	○
Mold temperature controller	○	○	○	○
Dehumidifier	○	○	○	○
Autoloader	○	○	○	○
Fumigated wooden package	○	○	○	○
Products taking plate	○	○	○	○
Feeding plate	○	○	○	○

Remarks: "●" Standard, "○" Option, "—" No.

Partner

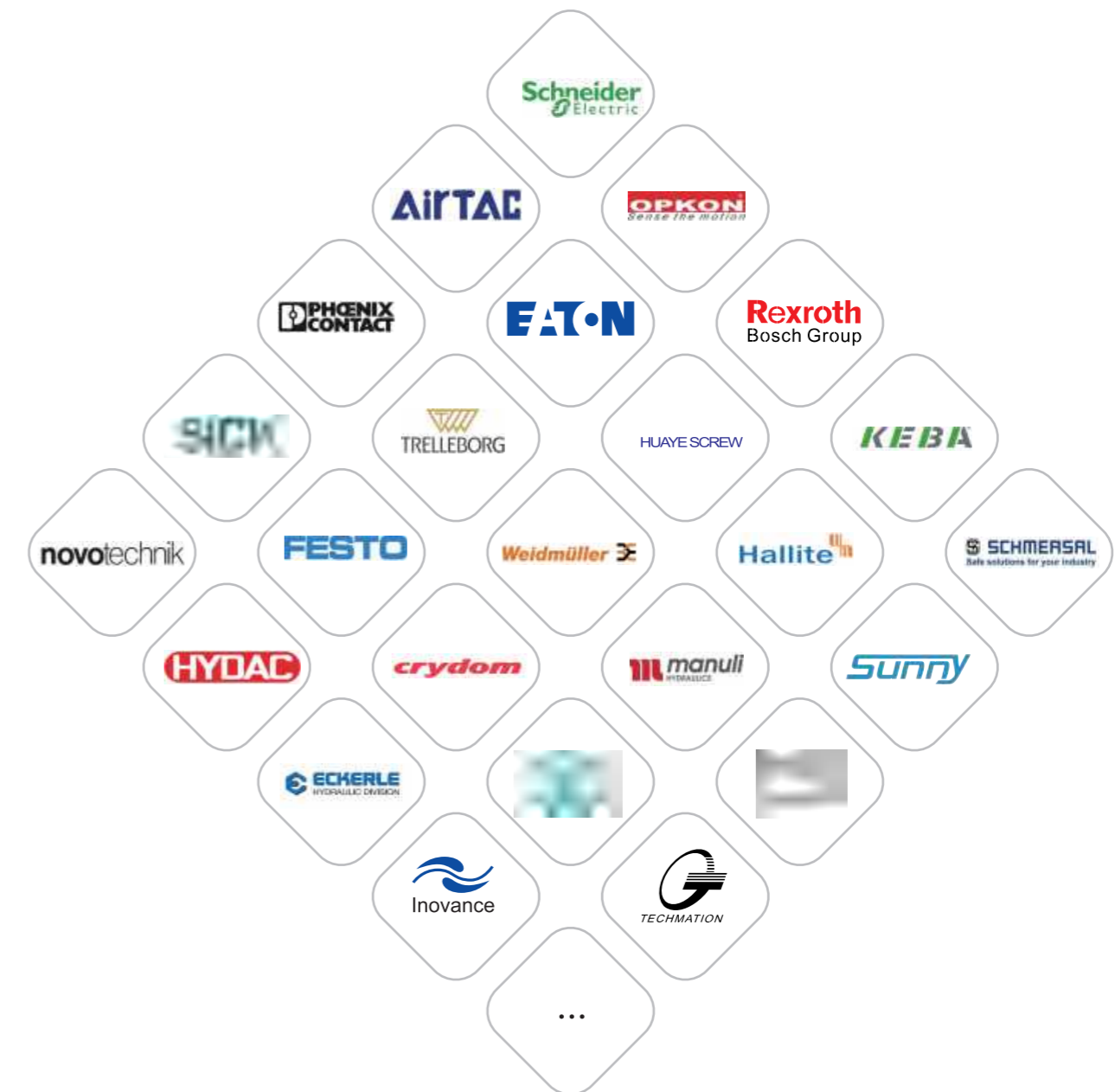

Meet the sun, moon and stars on the top of the mountain, create an infinite future together!